

DETTAGLIO G

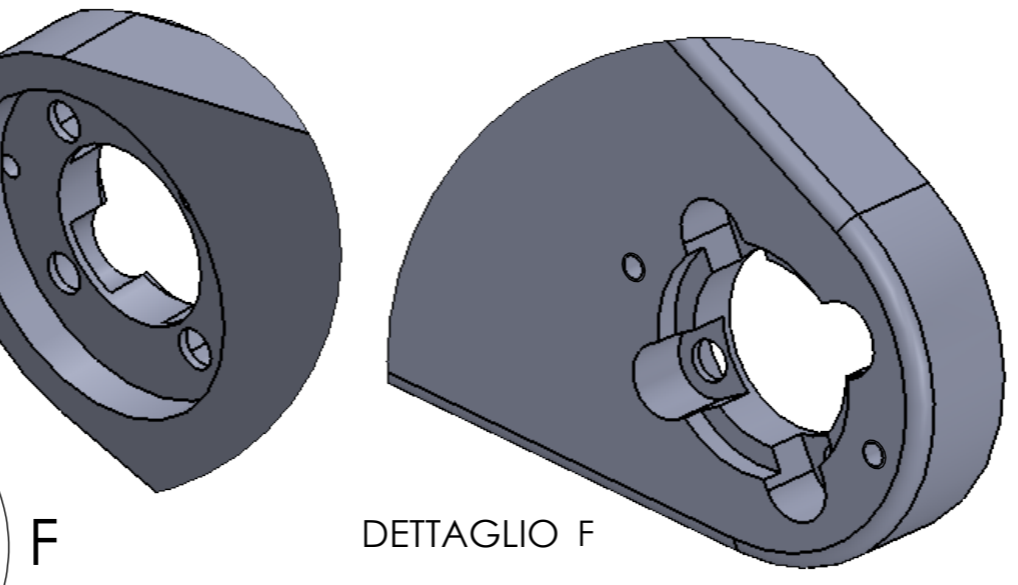
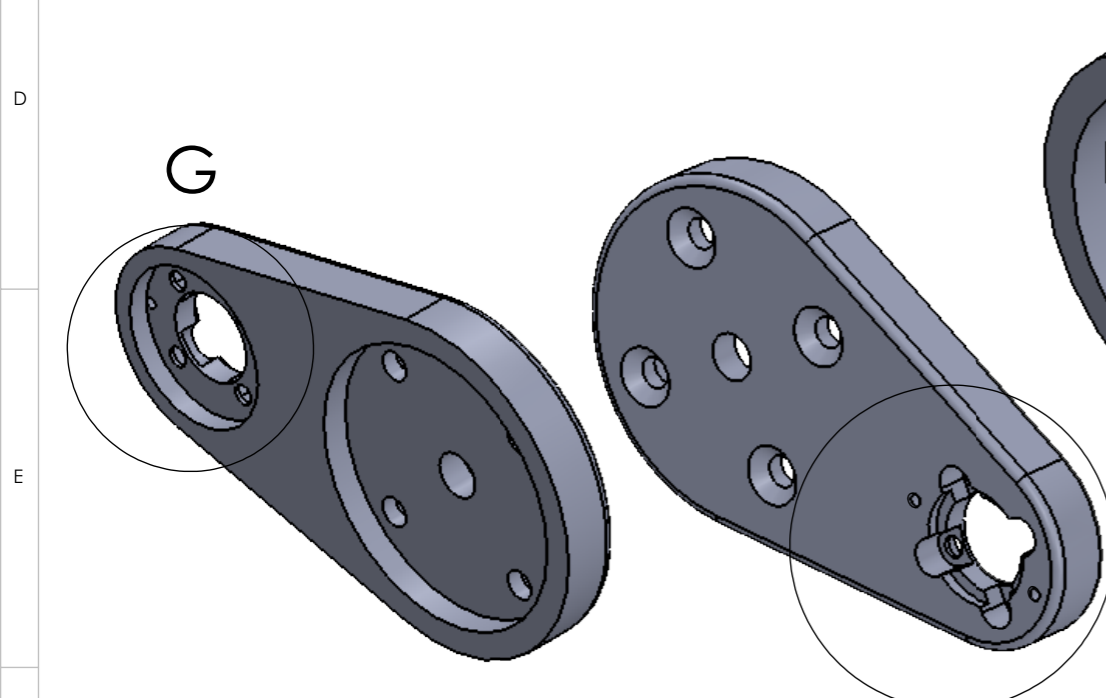
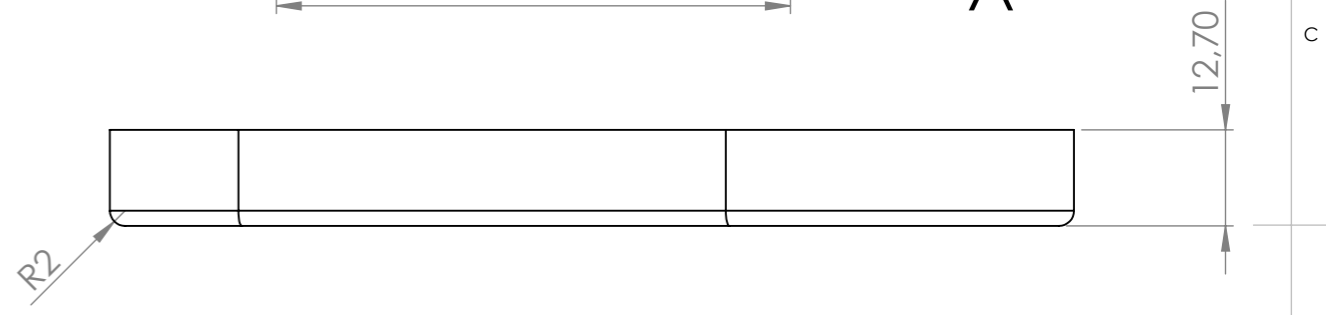

Tolleranze dove non segnate			REVISIONE	NOME	FIRMA	DATA	MATERIALE:	
Lunghezza	Fino 10mm	± 0,02mm	0	Pretto Giuliano		17/10/2017	Alluminio 6082	
	Fino 100mm	± 0,03mm						
	Fino 300mm	± 0,1mm						
	Oltre	± 1mm						
Diametro	Fori	H7	1	Pretto Giuliano		02/11/2017	Nome Adaptor Pluto/Robot	
	Alberi	h7	2	Pretto Giuliano		07/11/2017		
<small>THE INFORMATION CONTAINED IN THIS DRAWING IS THE SOLE PROPERTY OF KOLVER S.R.L. ANY REPRODUCTION IN PART OR AS A WHOLE WITHOUT THE WRITTEN PERMISSION OF KOLVER S.R.L. IS PROHIBITED.</small>			<h1>Kolver S.R.L.</h1>				Codice 010695/UR	
							FORMATO	A3

TRATTAMENTO: Burattatura e anodizzazione grigia